



## SPECIFICATIONS

# 6 INCH HIGH PRESSURE DRY PRIME

## Premier Pump Model 6x6CSH-VP-4045HF485-120

### Vacuum Assisted, Engine Driven, Heavy Duty Solids Handling Pump

#### **Pump Specifications:**

- Pump size: 6"X 6" AISI 150# flanges standard
- Suction Cover: ASTM A48 class 30 gray iron
- Wear Ring: ASTM A48 class 30 gray iron
- Volute Casing: ASTM A48 class 30 gray iron
- Volute Cleanout: Handhole type, ASTM A48 class 30 gray iron
- Backplate: ASTM A48 class 30 gray iron
- Bracket: ASTM A48 class 30 gray iron
- Mechanical Seal: Tungsten vs. Silicon Carbide seal faces, Viton elastomers, 300 series stainless steel hardware & spring, seal system designed for dry running
- Impeller: Enclosed type, two port, non clog, w/3 inch spherical solids handling capability. ASTM A48 class 30 gray iron
- Bearing Housing: ASTM A48 class 30 gray iron
- Pump-end Bearing: Single row ball – 6313-C3
- Drive-end Bearing: Single row ball – 6313-C3
- Shaft: 1144 Stressproof steel (Other metals available including: 17-4 PH corrosion resistant)
- Lip Seals: CR type, single lip: Bearings, SAE cover - Buna-N, Seal gland – Viton
- Midland 1300 series compressor. Lubricated by engine oil and cooled by engine water
- Separator Spool: Standard steel
- Air/Water chamber: Chamber designed to separate air and water before entering the pump case
- Venturi: Constructed of non-corrosive bronze
- Discharge check valve: Swing type, cast iron w/Buna-N disc (Viton optional)

**Optional Equipment and Materials:** Stainless Steel, CD4MCU & Ductile Iron

#### **Engine Specification:**

- Model: John Deere model 4045HF485
- 173 intermittent horsepower @ 2400 RPM
- Four cylinder, four cycle, water cooled diesel engine
- Governor: Mechanical
- Lubrication: Force Feed
- Air Cleaner: Filter element
- Fuel Tank: 120 US gallons
- Run time: Full load (1800 RPM) > 16 hours
- Starter: 12 volt electric



**Standard engine features:** Safety shutdown switches for low oil pressure and high temperature. Instrument panel with temperature and oil pressure gauge, ampmeter, hourmeter and tachometer. Muffler with rain cap. Engine to pump coupling: SAE3 housing with 10" rubber disc drive.

**Standard Skid:** Heavy duty fabricated steel frame. Integral fuel tank, lifting bale, lockable fuel tank, and one 1½" clean-out/drain plug

**Standard Trailer:** Heavy duty fabricated steel frame, integral fuel tank, fenders, lifting bail, lockable fuel cap, 6000# Anti-torsional axle, two (2) front adjustable leveling jacks and two (2) rear adjustable leveling jacks, one 1½" clean-out plug, fuel gauge, adjustable height tongue with easy conversion from ball hitch to Lunette eye

**Trailer Options:** DOT light package, work lights, special tires & wheels, dual axles, diamond plate fenders, surge brakes, lockable enclosed instrument panel, lockable enclosed engine housing, storage box, hose rack and more



Speed	Impeller Dia.	Style	Solids Dia.	N <sub>s</sub>	Suction	Discharge	No. vanes
VARIOUS	14"	ENCLOSED	3"	2120	6"	6"	2

Feet x .305 = Meters  
 Inches x 25.4 = Millimeters  
 GPM x .227 = Cubic Meters/Hour  
 GPM x 3.785 = Liters/Minute  
 HP x .746 = KW

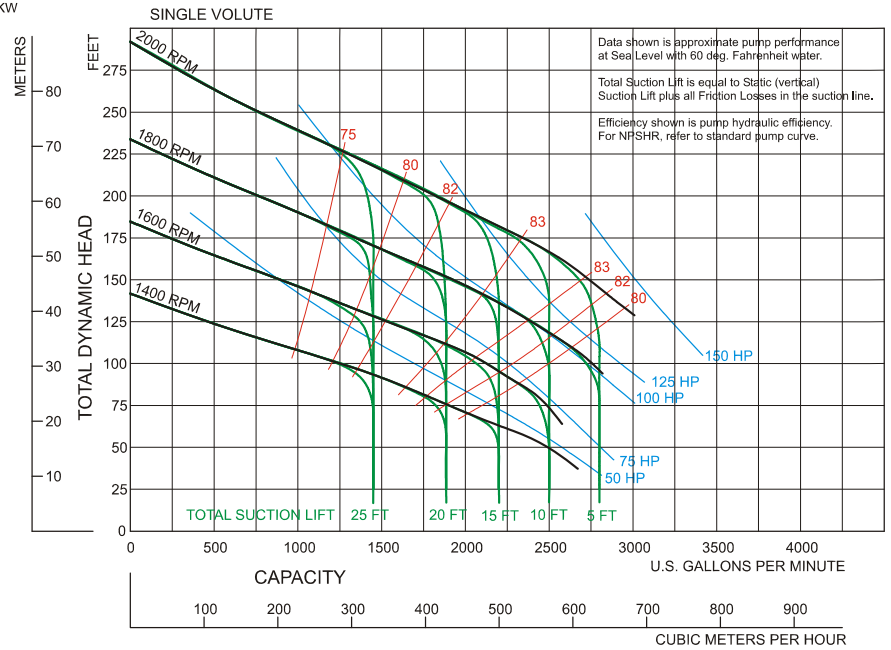

2/15/01

**6X6CS2H**

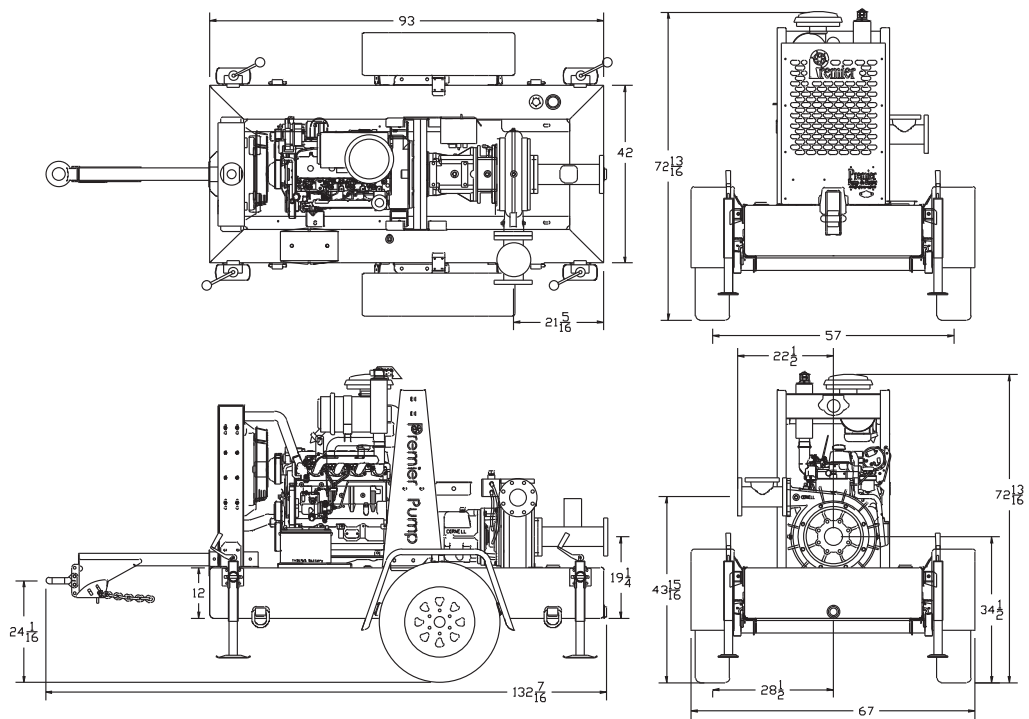



JOHN DEERE

**ENGINE PERFORMANCE CURVE**

Rating: Gross Power  
 Application: Industrial - Intermittent  
 Power Bulge - 0%  
 Torque Rise - 26%

**PowerTech Plus™ 4.5 L Engine**

Model: **4045HF485**

**JD Electronic Control**

**173 hp @ 2400 rpm**

**129 kW @ 2400 rpm**

[See Option Code Table]

STANDARD CONDITIONS

Air Intake Restriction ..... 12 in.H<sub>2</sub>O (3 kPa)  
 Exhaust Back Pressure ..... 30 in.H<sub>2</sub>O (7.5 kPa)

Gross power guaranteed within + or - 5% at SAE J1995 and ISO 3046 conditions:

- 77 °F (25 °C) air inlet temperature
- 29.31 in.Hg (99 kPa) barometer
- 104 °F (40 °C) fuel inlet temperature
- 0.853 fuel specific gravity @ 60 °F (15.5 °C)

Conversion factors:

- Power: kW = hp x 0.746
- Fuel: 1 gal = 7.1 lb, 1 L = 0.85 kg
- Torque: N•m = lb-ft x 1.356

All values are from currently available data and are subject to change without notice.

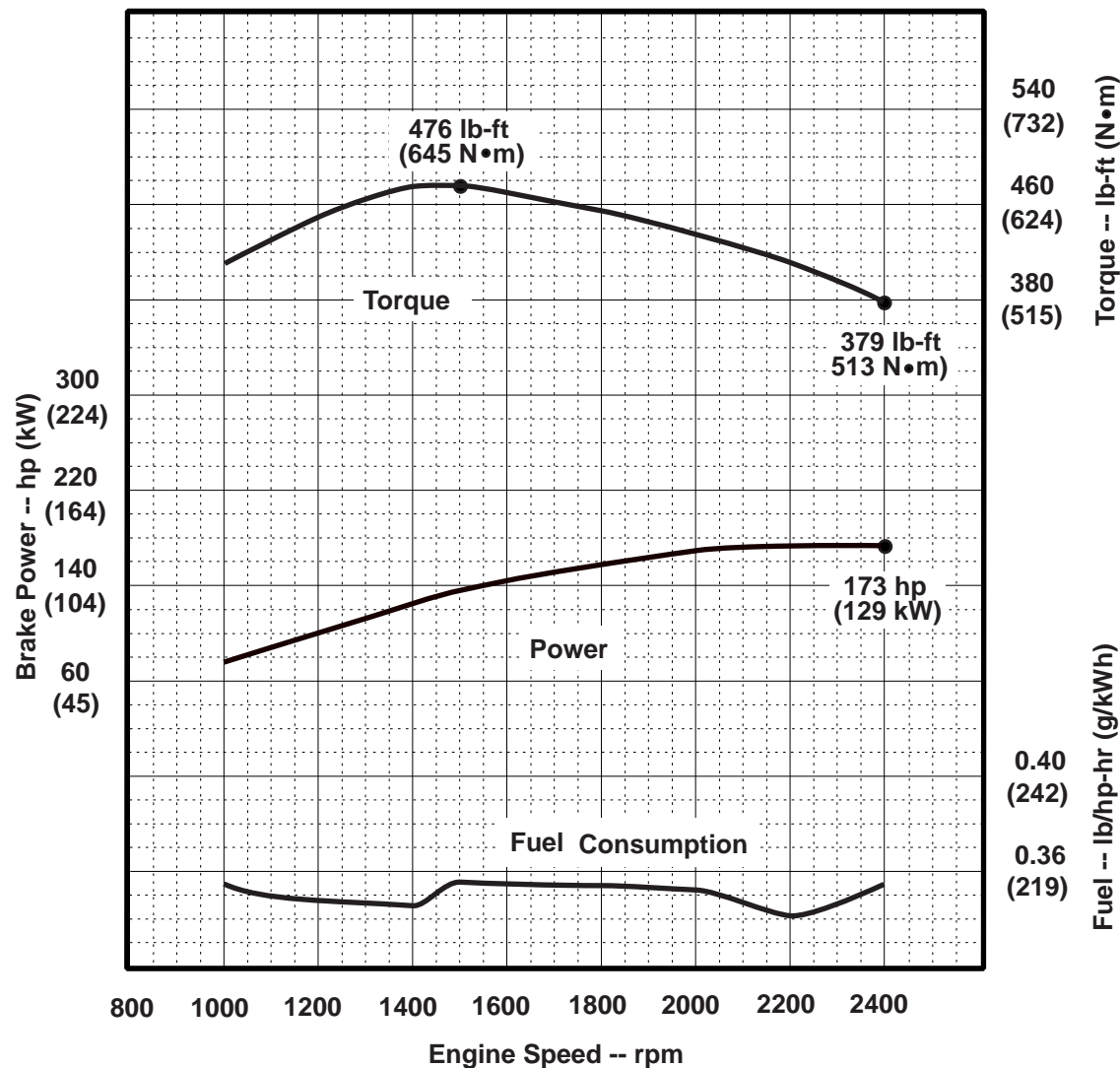

Notes:

Tier-3 Emission Certifications:	Certified by:
CARB; EPA; EU Ref: Engine Emission Label	<i>Brian L. Carlson</i> 11 DEC 06

\* Revised Data  
 Curve: 4045HF485173\_2400\_0\_26 ..... Sheet 1 of 2  
 December 2006

## Engine Installation Criteria

### General Data

Model ..... 4045HF485  
 Number of Cylinders ..... 4  
 Bore and Stroke--in. (mm)..... 4.19 (106) x 5.00 (127)  
 Displacement--in.<sup>3</sup> (L) .....275 (4.5)  
 Compression Ratio ..... 17.0 : 1  
 Valves per Cylinder--Intake/Exhaust ..... 2 / 2  
 Firing Order..... 1-3-4-2  
 Combustion System..... Unit Injection  
 Engine Type ..... In-line, 4-Cycle  
 Aspiration ..... Turbocharged  
 Charge Air Cooling System..... Air-to-Air  
 Engine Crankcase Vent System ..... Open

### Physical Data

Length--in. (mm) .....34.1 (867)  
 Width--in. (mm) .....26.8 (680)  
 Height--in. (mm) .....41.5 (1055)  
 Weight, dry--lb (kg) .....1083 (491)  
 (Includes flywheel housing, flywheel & electrics)  
 Center of Gravity Location  
     From Rear Face of Block(X-axis)--in.(mm).....9.8 (249)  
     Right of Crankshaft (Y-axis)--in. (mm).....2.2 (55)  
     Above Crankshaft (Z-axis)--in. (mm) .....5.7 (145)  
 Maximum Allowable Static Bending Moment at Rear Face  
     of Flywhl Hsg w/ 5-G Load--lb-ft (N•m) .....600 (814)  
 Thrust Bearing Load Limit --lb (N) Forward Rearward  
     Intermittent.....899 (4000).....450 (2000)  
     Continuous .....495 (2200).....225 (1000)  
 Max. Front of Crank. Torsional Vibration--DDA.....0.25  
 Max. Continuous Damper Temp--°F (°C) .....180 (82)

### Electrical System

**12 Volt    24 Volt**

Min. Battery Capacity (CCA)--amp..... 800 ..... 570  
 Max. Allow. Starting Circuit Resist.--Ohm 0.0012 ..... 0.002  
 Starter Rolling Current  
     At 32 °F ( 0 °C)--amp ..... 920 ..... 600  
     At -22 °F (-30 °C)--amp ..... 1300 ..... 700  
 Min. Voltage at ECU during Cranking--volts..... 6 ..... 10  
 Maximum ECU Temperature--°F (°C) .....221 (105)  
 Max. VTG Actuator Surface Temp.--°F (°C) .....356 (180)  
 Maximum Harness Temperature--°F (°C) .....248 (120)

### Air System

Maximum Allowable Temp Rise--Ambient Air to  
     Engine Inlet--°F (°C) .....15 (8)  
 Maximum Air Intake Restriction:  
     Dirty Air Cleaner--in. H<sub>2</sub>O (kPa).....25 (6.25)  
     Clean Air Cleaner--in. H<sub>2</sub>O (kPa).....15 (3.75)  
 Engine Air Flow--ft<sup>3</sup>/min (m<sup>3</sup>/min) .....402 (11.4)  
 Air Cleaner Efficiency--% .....99.9

### Charge Air Cooling System

Air/Air Exch'r. Heat Rej.--Btu/min(kW) ..... 1719 (30)  
 Compressor Discharge Temp.(Rated)  
     @ 77 °F (25°C) Ambient Air--°F (°C).....421 (216)  
 Compressor Discharge Temp.(Max.)--°F (°C)  
     @ any Ambient--°F (°C) ..... 500 (260)\*  
 Max. Pressure Drop, thru CAC--in.H<sub>2</sub>O (kPa) ..... 52 (13)  
 Min. Pressure Drop, thru CAC--in.H<sub>2</sub>O (kPa) ..... 20 (5)  
 Intake Manifold Pressure--psi (kPa) ..... 25 (175)  
 Max CAC Out Temp @ 77°F (25°C) Amb.--°F (°C) 126(52)  
 Min CAC Out Temp @ 77°F (25°C) Amb.--°F (°C) 119 (49)  
 Max CAC Out Temp @ any Ambient--°F (°C) ..... 190 (88)

### Cooling System

Engine Heat Rejection--BTU/min (kW) ..... 4024 (71)  
 Coolant Flow--gal/min (L/min)..... 87 (330)  
 Thermostat Start to Open--°F (°C)..... 180 (82)  
 Thermostat Fully Open--°F (°C).....203 (95)  
 Engine Coolant Capacity--qt (L) ..... 9 (8.5)  
 Minimum Pressure Cap--psi (kPa)..... 14.5 (100)  
 Maximum Top Tank Temp--°F (°C) ..... 230 (110)  
 Minimum Coolant Fill Rate--gal/min (L/min) ..... 3 (11)  
 Minimum Air-to-Boil Temperature--°F (°C)..... 117 (47)  
 Minimum Pump Inlet Pressure--psi (kPa) ..... 4.4 (30)

### Exhaust System

Exhaust Flow--ft<sup>3</sup>/min (m<sup>3</sup>/min)..... 884 (25)  
 Exhaust Temperature--°F (°C).....768 (409)  
 Max. Exhaust Restriction--in. H<sub>2</sub>O (kPa) ..... 30 (7.5)  
 Min. Exhaust Restriction---in. H<sub>2</sub>O (kPa)..... 12 (3)  
 Max. Bend. Moment on Turbo Out.--lb-ft (N•m) ..... 5.2 (7)  
 Max. Shear on Turbo Outlet--lb (kg) ..... 24 (11)

### Fuel System

ECU Description ..... L14 Controller\*  
 Fuel Injection Pump ..... Denso HP3  
 Governor Type.....Electronic  
 Total Fuel Flow--lb/hr (kg/hr) ..... 148 (67.0)  
 Fuel Consumption--lb/hr (kg/hr) ..... 62 (28)  
 Max. Fuel Inlet Temperature--°F (°C) ..... 176 (80)  
 Fuel Temp. Rise, Inlet to Return--°F (°C) ..... 92 (51)  
 Max. Fuel Inlet Restriction--in. H<sub>2</sub>O (kPa) ..... 80 (20)  
 Max. Fuel Inlet Pressure--in. H<sub>2</sub>O (kPa) ..... NA (NA)  
 Max. Fuel Return Pressure--in. H<sub>2</sub>O (kPa) ..... 80 (20)

### Lubrication System

Oil Pressure at Rated Speed--psi (kPa) ..... 58 (400)  
 Oil Pressure at Low Idle--psi (kPa) ..... 15 (105)  
 Max. Oil Carryover in Blow-by--lb/hr (g/hr) ..... 0.002 (1.0)  
 Max. Airflow in Blow-by--gal/min (l/min)..... 26 (100)  
 Max. Crankcase Pressure--in. H<sub>2</sub>O (kPa)..... 2 (0.5)

### Performance Data

Rated Power--hp (kW) ..... 173 (129)  
 Rated Speed--rpm ..... 2400  
 Breakaway Speed--rpm ..... 2470  
 Fast Idle Speed--rpm ..... 2600  
 Peak Torque--lb-ft (N•m)..... 476 (645)  
 Peak Torque Speed--rpm ..... 1500  
 Low Idle Speed--rpm ..... 800  
 BMEP--psi (kPa).....208 (1433)  
 Friction Power @ Rated Speed--hp (kW) ..... 17 (13)  
 Altitude Capability--ft (m) ..... 10,000 (3050)  
 Ratio--Air : Fuel ..... 27 : 1  
 Smoke @ Rated Speed--Bosch No. ....<1  
 Noise--dB(A) @ 1 m ..... 90.3  
 Power Bulge--% ..... 0  
 Power Bulge Speed--rpm ..... NA  
 Torque Rise--% ..... 26

Engine Speed rpm	Power hp (kW)	Torque lb-ft (N•m)	BSFC lb/hp-hr (g/kWh)
2400	173 (129)	379 (513)	0.355 (216)
2200	173 (129)	413 (559)	0.341 (208)
2000	167 (125)	439 (595)	0.351 (214)
1800	156 (116)	454 (616)	0.353 (215)
1600	143 (107)	470 (637)	0.353 (215)
1500	135 (101)	476 (645)	0.356 (217)
1400	127 (95)	476 (645)	0.346 (211)
1200	103 (77)	450 (611)	0.348 (212)
1000	79 (59)	413 (559)	0.355 (216)

All values at rated speed and power with standard options unless otherwise noted.

\* Revised Data  
 Curve: 4045HF485173\_2400\_0\_26 ..... Sheet 2 of 2  
 December 2006