



SPECIFICATIONS

4 INCH DRY PRIME

Premier Pump Model 4x4CS2HA-VP-4045TF280-60

Vacuum Assisted, Engine Driven, Heavy Duty Solids Handling Pump

Pump Specifications:

- Pump size: 4"X 4" AISI 150# flanges standard
- Suction Cover: ASTM A48 class 30 gray iron
- Wear Ring: ASTM A48 class 30 gray iron
- Volute Casing: ASTM A48 class 30 gray iron
- Volute Cleanout: Handhole type, ASTM A48 class 30 gray iron
- Backplate: ASTM A48 class 30 gray iron
- Bracket: ASTM A48 class 30 gray iron
- Mechanical Seal: Tungsten vs. Silicon Carbide seal faces, Viton elastomers, 300 series stainless steel hardware & spring, seal system designed for dry running
- Impeller: Enclosed type, two port, non clog, w/3 inch spherical solids handling capability. ASTM A48 class 30 gray iron
- Bearing Housing: ASTM A48 class 30 gray iron
- Pump-end Bearing: Single row ball – 6313-C3
- Drive-end Bearing: Single row ball – 6313-C3
- Shaft: 1144 Stressproof steel (Other metals available including: 17-4 PH corrosion resistant)
- Lip Seals: CR type, single lip: Bearings, SAE cover - Buna-N, Seal gland – Viton
- Midland 1300 series compressor. Lubricated by engine oil and cooled by engine water
- Separator Spool: Standard steel
- Air/Water chamber: Chamber designed to separate air and water before entering the pump case
- Venturi: Constructed of non-corrosive bronze
- Discharge check valve: Swing type, cast iron w/Buna-N disc (Viton optional)

Optional Equipment and Materials: Stainless Steel, CD4MCU & Ductile Iron

Engine Specification:

- Model: John Deere model 4045TF280 Tier 3
- 80 intermittent horsepower @ 2400 RPM
- Four cylinder, four cycle, water cooled diesel engine
- Governor: Mechanical
- Lubrication: Force Feed
- Air Cleaner: Filter element
- Fuel Tank: 60 US gallons
- Run time: Full load (1800 RPM) ~ 24 hours
- Starter: 12 volt electric



Pictured: 6x6CS2-VP-4045DF270-T60

Standard engine features: Safety shutdown switches for low oil pressure and high temperature. Instrument panel with temperature and oil pressure gauge, ampmeter, hourmeter and tachometer. Muffler with rain cap. Engine to pump coupling: SAE3 housing with 10" rubber disc drive.

Standard Skid: Heavy duty fabricated steel frame. Integral fuel tank, lifting bale, lockable fuel tank, and one 1½" clean-out/drain plug

Standard Trailer: Heavy duty fabricated steel frame, integral fuel tank, fenders, lifting bail, lockable fuel cap, 3500# Anti-torsional axle, two (2) front adjustable leveling jacks and two (2) rear adjustable leveling jacks, one 1½" clean-out plug, fuel gauge, adjustable height tongue with easy conversion from ball hitch to Lunette eye

Trailer Options: DOT light package, work lights, special tires & wheels, dual axles, diamond plate fenders, surge brakes, lockable enclosed instrument panel, lockable enclosed engine housing, storage box, hose rack and more



Speed	Impeller Dia.	Style	Solids Dia.	N _S	Suction	Discharge	No. vanes
VARIOUS	12"	ENCLOSED	3"	1540	4"	4"	2

Feet x .305 = Meters
 Inches x 25.4 = Millimeters
 GPM x .227 = Cubic Meters/Hour
 GPM x 3.785 = Liters/Minute
 HP x .746 = KW

SINGLE VOLUTE

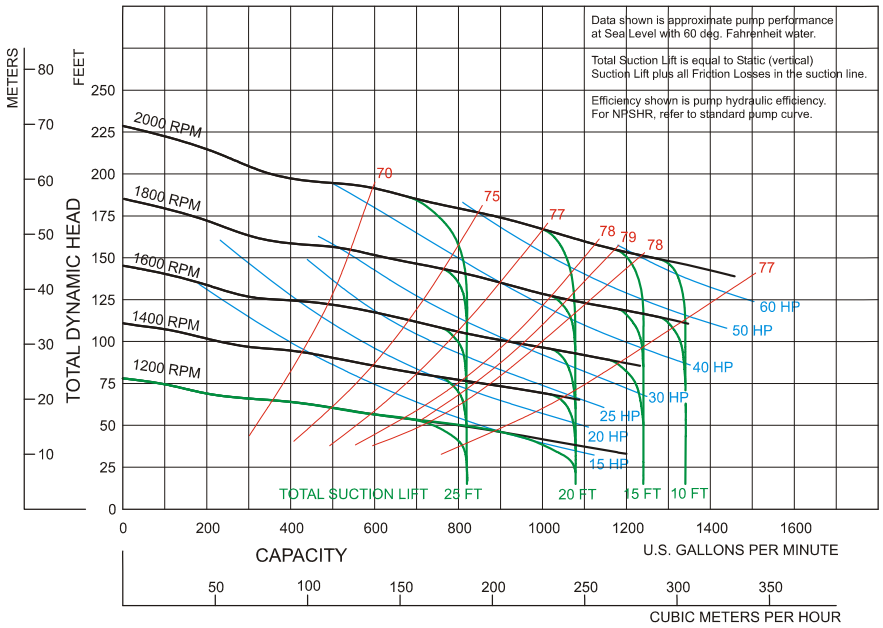

3/14/01

4X4CS2HA

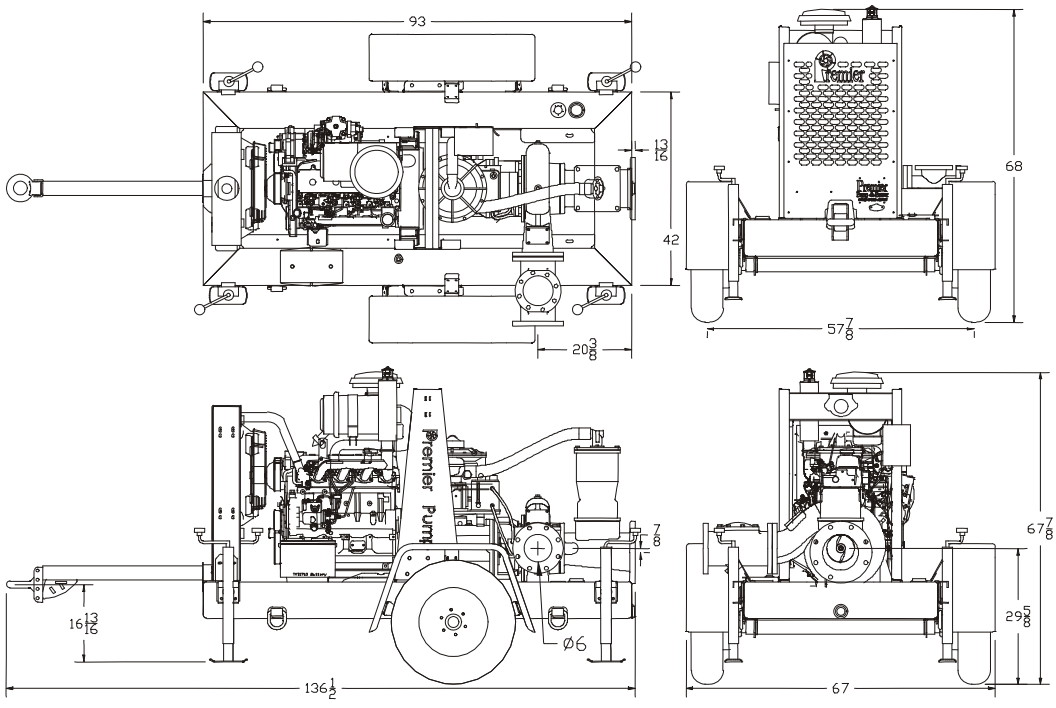



JOHN DEERE

ENGINE PERFORMANCE CURVE

Rating: Gross Power

Application: Industrial
Intermittent / Continuous

PowerTech M™ 4.5 L Engine

Model: 4045TF280

80 hp @ 2400 rpm

60 kW @ 2400 rpm

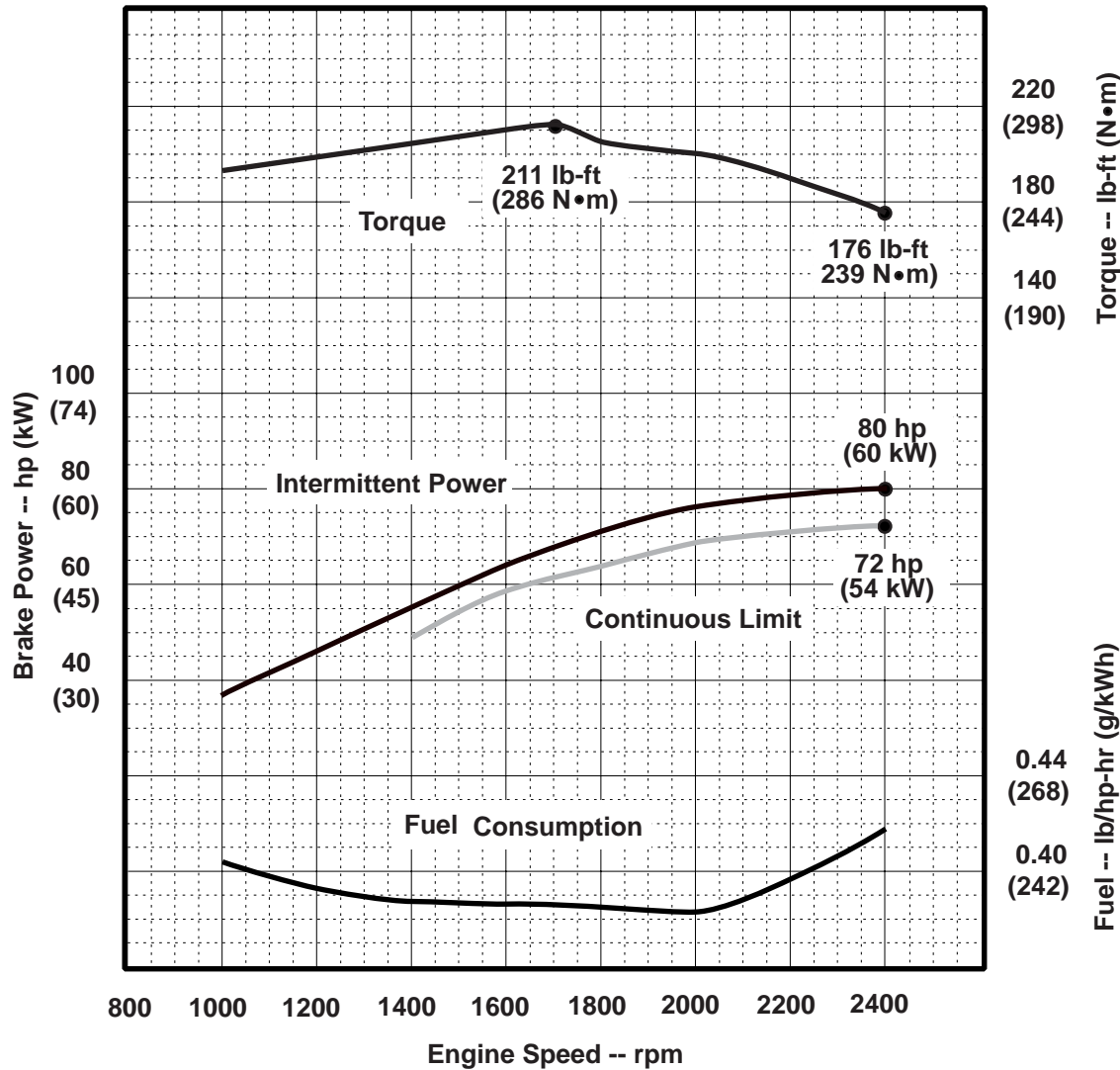

Air Intake Restriction 12 in.H₂O (3 kPa)
 Exhaust Back Pressure 30 in.H₂O (7.5 kPa)

Gross power guaranteed within + or - 5% at SAE J1995 and ISO 3046 conditions:

- 77 °F (25 °C) air inlet temperature
- 29.31 in.Hg (99 kPa) barometer
- 104 °F (40 °C) fuel inlet temperature
- 0.853 fuel specific gravity @ 60 °F (15.5 °C)

Conversion factors:

- Power: kW = hp x 0.746
- Fuel: 1 gal = 7.1 lb, 1 L = 0.85 kg
- Torque: N•m = lb-ft x 1.356

All values are from currently available data and are subject to change without notice.

Notes:

Tier-3 Emission Certifications:

Certified by:

CARB; EPA; EU
 Ref: Engine Emission Label

Vincent...
 08-24-07

* Revised Data

Curve: 4045TF28080_2400..... Sheet 1 of 2
 August 2007

